

MULTITEL



MX235



- Commandes électro-hydrauliques proportionnelles avec la possibilité de réglage de la vitesse de tous les mouvements, aussi bien du sol que de la nacelle.
- Parallélogramme hydraulique de maintien à niveau nacelle.
- Sortie hydraulique des deux éléments télescopiques du bras.
- Chemins de câbles internes au bras.
- Clapets anti-retour sur tous les mouvements.
- Pompe manuelle pour manoeuvre d'urgence.
- Arrêt coup de poing en cas de panne.
- Démarrage et arrêt du moteur depuis la nacelle.
- Dispositif interdiction sortie télescopique et rotation tourelle avec bras à repos.
- Dispositif de centrage automatique du bras pour la mise au repos.



- Proportional electro-hydraulic controls from both control posts.
- Hydraulic cage levelling.
- Synchronous multi-stage telescope cylinders.
- Internal hose and cable ducts.
- Hydraulic check valves on all movements.
- Emergency hand pump.
- Engine start-stop on both control stations.
- Telescope retainer and turret rotation blocking in transport position.
- Automatic centering device for the boom stowage.



- Elektro-Hydraulische Proportionalsteuerung mit Geschwindigkeitsregelung für alle Funktionen, von Korb- und Bodenbedienung.
- Hydraulische Korbnivellierung.
- Synchron-ausfahrende Mehrstufen Teleskop-Zylinder.
- Innenliegende Kabel- und Schlauchverlegung.
- Hydraulische Sperrventile auf jede Bewegung.
- Not-Handpumpe.
- Not-Stop an beide Steuerpulte.
- Fahrzeug Start-Stop an beide Steuerpulte.
- Teleskopausfahr- und Turmdreh Sperre in Transportstellung.
- Automatische Vorrichtung für die Zentrierung des Auslegers um das Gerät in Ruhstellung zu bringen.



- Comando elettroidraulico proporzionale con regolazione della velocità di tutti i movimenti sia dal cestello che da terra.
- Parallelismo idrostatico del cestello.
- Uscita oleodinamica degli sfili telescopici del braccio.
- Tubi e cavi installati all'interno del braccio.
- Valvole di blocco su ogni movimento.
- Pompa a mano di emergenza.
- Pulsante di arresto in caso di avaria.
- Avviamento e arresto del motore dal cestello.
- Dispositivo di interdizione uscita telescopica e rotazione torretta con braccio a riposo.
- Dispositivo di centraggio automatico del braccio per la messa a riposo.

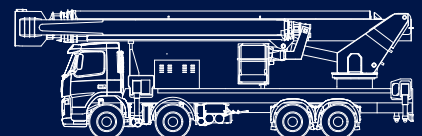
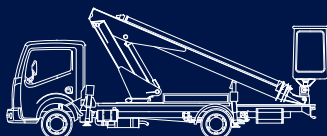

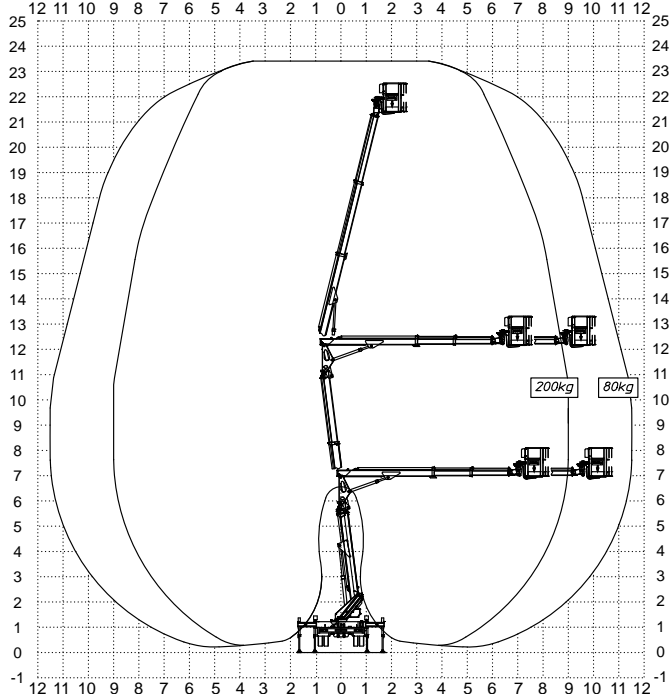

Subject to change without notice • Technische Änderungen vorbehalten!

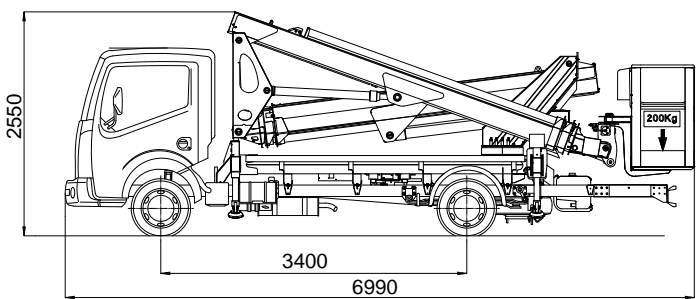
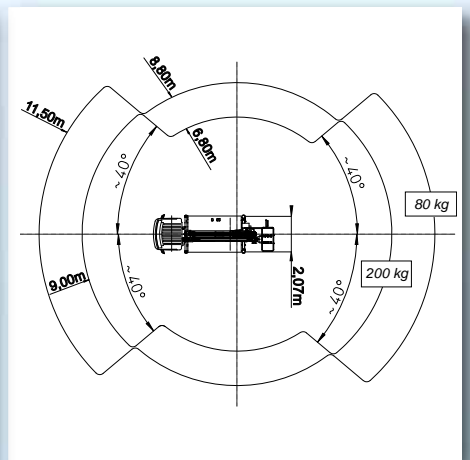
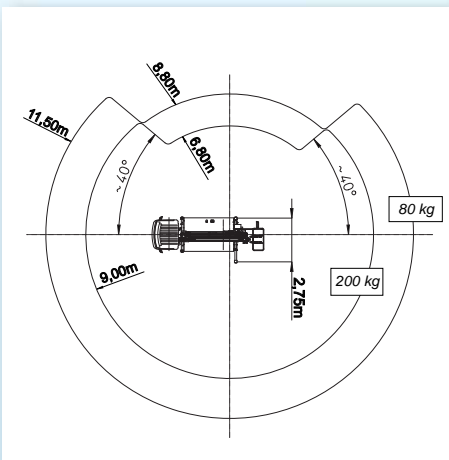
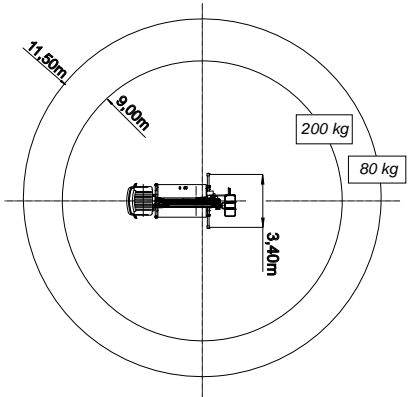

MX235

Hauteur de travail	Max working height	Maximale Arbeitshöhe	Altezza max di lavoro	23,40 m
Hauteur plancher nacelle	Maximum platform height	Maximale Plattformhöhe	Altezza piano calpestio cestello	21,40 m
Déport maxi de travail	Max working outreach	Maximale seitliche Reichweite	Sbraccio max di lavoro	9,00 m (200kg) - 11,50 m (80kg)
Rotation de la tourelle	Turret rotation	Schwenkbereich	Rotazione torretta	400°
Rotation de la nacelle	Cage rotation	Hydraulische Korbdrehung	Rotazione idraulica del cestello	60°+60°
Sortie télescopique des bras	Boom telescopic amplitude	Teleskopausschub	Escursione telescopica dei bracci	10,71 m
Dimensions maxi nacelle	Max cage dimensions	Max Arbeitskorbabmessungen	Dimensioni max del cestello	1,40 x 0,70 x 1,10 m
Charge utile en nacelle	Safe working load on cage	Tragfähigkeit	Portata cestello	200 kg
Dévers maxi admissible	Max admissible slope	Maximale zulässige Neigung	Pendenza ammissibile	1°

MULTITEL
Since 1911



NOLOGAP
NOLEGGIO PIATTAFORME AEREE

Nologap Srl
Via Circonvallazione, 162
10026 SANTENA - TO -
Tel. 011 9493840